

MID-CONTINENT I N S T R U M E N T S

.....

INSTALLATION MANUAL AND OPERATING INSTRUCTIONS

MD41-() Series GPS Annunciation Unit For Garmin GNS 430/430W/530/530W VHF Communication and Navigation Management System

MD41-1484W	14VDC	Horizontal Mount
MD41-1488W	28VDC	Horizontal Mount
MD41-1494W	14VDC	Vertical Mount
MD41-1498W	28VDC	Vertical Mount

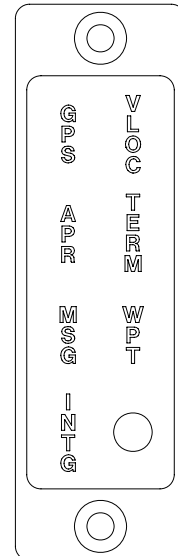
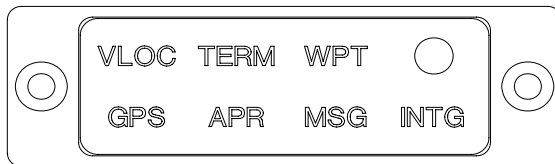

MID-CONTINENT INST. CO., INC

MANUAL NUMBER 9016478

Revision History

ECO	Rev.	Date	Detail
	N/R	01/19/07	Initial release.
	A	02/15/07	J1 connector was 9016475, now 9016479.
	B	03/12/07	Corrected section 4.1 to show proper pins, corrected mating connector rear view.
4828	C	4/24/07	Correct connector schematic pinout in section 1.2.5. Add -1494W and -1498W versions.

TABLE OF CONTENTS

SECTION 1	GENERAL DESCRIPTION
1.1	INTRODUCTION
1.2	SPECIFICATIONS, TECHNICAL
1.2.1	PHYSICAL CHARACTERISTICS
1.2.2	ENVIRONMENTAL CHARACTERISTICS
1.2.3	SPECIFICATIONS, ELECTRICAL
1.2.4	FRONT PANEL CONTROLS AND ANNUNCIATIONS
1.2.4.1	CONTROLS
1.2.4.2	ANNUNCIATIONS
1.2.5	INTERFACE
1.2.6	EQUIPMENT LIMITATIONS
1.2.7	MAJOR COMPONENTS
SECTION 2	INSTALLATION CONSIDERATIONS
2.1	COOLING
2.2	EQUIPMENT LOCATION
2.3	ROUTING OF CABLES
SECTION 3	INSTALLATION PROCEDURE
3.1	GENERAL INFORMATION
3.2	UNPACKING AND INSPECTING
3.3	MOUNTING THE MD41-()
3.4	INSTALLATION LIMITATIONS
SECTION 4	POST INSTALLATION CHECKOUT
4.1	PRE-INSTALLATION TEST
4.2	OPERATING INSTRUCTIONS
FIGURES	LIST OF ILLUSTRATIONS
3.1	SCHEMATIC PINOUT, 15 PIN HIGH DENSITY D-SUB
3.2	OUTLINE DRAWING
3.3	INSTRUMENT PANEL MOUNTING
3.4	WIRING DIAGRAM, MD41-1484W/1488W/1494W/1498W
APPENDIX	RTCA DO-160C ENVIRONMENTAL QUALIFICATION FORM

SECTION 1 GENERAL DESCRIPTION

1.1 INTRODUCTION

The MD41-() is a compact, self-contained GPS Annunciation unit. This unit displays status annunciation received from the Garmin GNS 430/430W/530/530W series GPS navigation management systems.

Features include dual 20,000 hour lamps used for all annunciations along with automatic photocell dimming. An external annunciation dimming adjustment is provided for balancing low-level light conditions.

1.2 TECHNICAL SPECIFICATIONS

1.2.1 PHYSICAL CHARACTERISTICS

Mounting:	Front mount, panel
Width:	2.45 inches
Height:	0.75 inches
Depth:	2.60 inches (max)
Weight:	0.2 pounds

1.2.2 ENVIRONMENTAL CHARACTERISTICS

TSO Compliance:	TSO C129
Applicable Documents:	RTCA DO-160C, DO-208
Operating Temperature Range:	-55°C to +70°C
Humidity:	95% Non-Condensing
Altitude Range:	0 to 55,000 ft.
Vibration:	RTCA DO-160C, Cat. M and N
Operational Shock:	Rigid Mounting, 6G Operational 15 G Crash Safety

1.2.3 ELECTRICAL SPECIFICATIONS

Design	All Solid State
MD41-1484W (14VDC)	0.30 Amps
MD41-1488W (28VDC)	0.25 Amps
MD41-1494W (14VDC)	0.30 Amps
MD41-1498W (28VDC)	0.25 Amps

1.2.4 FRONT PANEL CONTROLS AND ANNUNCIATIONS

1.2.4.1 ANNUNCIATIONS

VLOC	NAV or ILS information presented on the HSI or CDI
GPS	GPS information presented on the HSI or CDI
MSG	ON indicates message(s) active.
WPT	ON indicates reaching the arrival waypoint.
TERM	ON indicates aircraft is within 30 miles of departure or arrival airport
APR	ON indicates the approach is active.
INTG	ON indicates GPS receiver detected a position error or is unable to calculate the integrity of the position

1.2.5 INTERFACE

INTG annunciation J1 Pin 1	Requires a logic low to annunciate
WPT annunciation J1 Pin 2	Requires a logic low to annunciate when in VOR/ILS mode
MSG annunciation J1 Pin 3	Requires a logic low to annunciate
TERM annunciation J1 Pin 4	Requires a logic low to annunciate
APR annunciation J1 Pin 6	Requires a logic low to annunciate
VLOC annunciation J1 Pin 7	Receives ground from GNS 430/530
GPS annunciation J1 Pin 8	Receives ground from GNS 430/530 when in GPS mode.
Lamp Test J1 Pin 10	Receives ground from remote test switch to light all annunciations (optional connection)
J1 Pin 15	Ground

1.2.6 EQUIPMENT LIMITATIONS

The MD41-() series control units contain specific dash numbers to be used with various GPS receivers or Navigation Management Systems. The installer must match the correct controller part number with the system being installed.

The conditions and tests required for TSO approval of this article are minimum performance standards. It is the responsibility of those desiring to install this article either on or within a specific type or class of aircraft to determine that the aircraft installation conditions are within the TSO standards. The article may be installed only if further evaluation by the applicant documents an acceptable installation and is approved by the Administrator.

The MD41-1484W/1488W/1494W/1498W are TSO certified and approved for use with the Garmin GNS 430/430W/530/530W system. This includes the (A), (W) and TAWS system versions of the Garmin equipment. Any attempts to install the listed units in an installation other than the GNS 430/530 system is prohibited.

This will void the TSO.

NOTE: If the MD41-() is disconnected or removed from the aircraft, it will not affect the operation of the GNS 430/430W/530/530W.

1.2.7 MAJOR COMPONENTS

This system is comprised of one major component, the MD41-1484W/1488W/1494W/1498W GPS Annunciation Control Units.

SECTION 2: INSTALLATION CONSIDERATIONS

2.1 COOLING

No direct cooling is required. As with any electronic equipment, overall reliability may be increased if the MD41-() is not located near any high heat source or crowded next to other equipment. Means of providing a gentle airflow will be a plus.

2.2 EQUIPMENT LOCATION

The MD41-() must be mounted as close to the pilot's field of view as possible. The preferable location is near the HSI/CDI that will be displaying the GPS/VLOC information. The unit depth, with connector attached, must also be taken into consideration. Note: Unlike previous versions of the MD41 Annunciation Control Units (ACU), the transfer relays are not required since the GNS 430/530 handles all switching between GPS, VOR and ILS. This has allowed for a smaller size ACU that now provides more options for panel mounting.

2.3 ROUTING OF CABLES

Care must be taken not to bundle the MD41-() logic and low level signal lines with any high energy sources. Examples of these sources include 400 HZ AC, Comm, DME, HF and transponder transmitter coax. Always use shielded wire when shown on the installation print.

Avoid sharp bends in cabling and routing near aircraft control cables.

SECTION 3: INSTALLATION PROCEDURES

3.1 GENERAL INFORMATION

This section contains interconnect diagrams, mounting dimensions and other information pertaining to the installation of the MD41-(). After installation of cabling and before installation of the equipment, ensure that power is applied only to the pins specified in the interconnect diagram.

3.2 UNPACKING AND INSPECTING EQUIPMENT

When unpacking equipment, make a visual inspection for evidence of damage incurred during shipment. The following parts should be included:

1. MD41-1484W (14VDC) or MD41-1488W (28VDC) Horiz. Mount
MD41-1494W (14VDC) or MD41-1498W (28VDC) Vertical Mount
2. Installation kit P/N 9016480 consisting of the following items:
 - A. J1 Connector Kit (15 pin) MCI P/N 9016479
 - B. 2 ea mounting brackets MCI P/N 8018483
 - C. 4 ea 4-40x 1/2 pan Phillips screws MCI P/N 90-416-00011
 - D. 2 ea 4-40x 9/16 flat Phillips screws MCI P/N 90-418-10011
 - E. 1 ea panel cutout template MCI P/N 8018954
3. Installation Manual MCI P/N 9016478

3.3 MOUNTING THE MD41-()

Plan a location in the aircraft for the MD41-() to be mounted as close to the pilot's field of view as possible. The preferable location is near the HSI/CDI that will be displaying the GPS information. Avoid mounting close to heater vents or other high heat sources. Allow a clearance of at least 3 inches from back of unit for plug removal.

Use the dimensions shown in figure 3-3 to prepare opening and screw holes for the ACU. A file template has been provided to use for these measurements and hole cutout. Carefully measure the locations for the screw holes and mark the drill locations with a center punch. Drill all six holes. A steel template (P/N 8018954) is supplied to aid in locating holes and cutting out the panel. The template may be mounted to the instrument panel to allow a file to be used to complete the cutout area. The front plate of the ACU has a recessed area on the back so a flat head screw is not absolutely necessary. Attach the mounting brackets to the rear side of the instrument panel with four 4-40x1/2 pan-head screws. Insert the ACU through the front of instrument panel and fasten with two 4-40 x 9/16 flat-head screws.

3.4 INSTALLATION LIMITATIONS

Wire the aircraft harness according to figure 3-3. Use at least 24 AWG wire for all connections. Avoid sharp bends and routing cable near high-energy sources. Care must be taken to tie the harness away from aircraft controls and cables. Normal installation techniques should be applied. Also see equipment limitations, section 1.2.6.

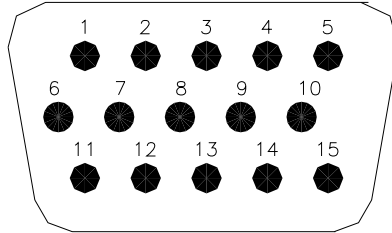

REAR VIEW OF MATING CONNECTOR

Connector Pinout			
Pin #		Pin #	
1	INTG Annun.	9	Reserved
2	WPT Annun.	10	Lamp Test
3	MSG Annun.	11	Reserved
4	TERM Annun.	12	Reserved
5	28 VDC Power	13	Reserved
6	APR Annun.	14	Reserved
7	VLOC Annun.	15	Ground
8	GPS Annun.		

FIGURE 3-1 SCHEMATIC PINOUT, 15 PIN HIGH DENSITY D-SUB

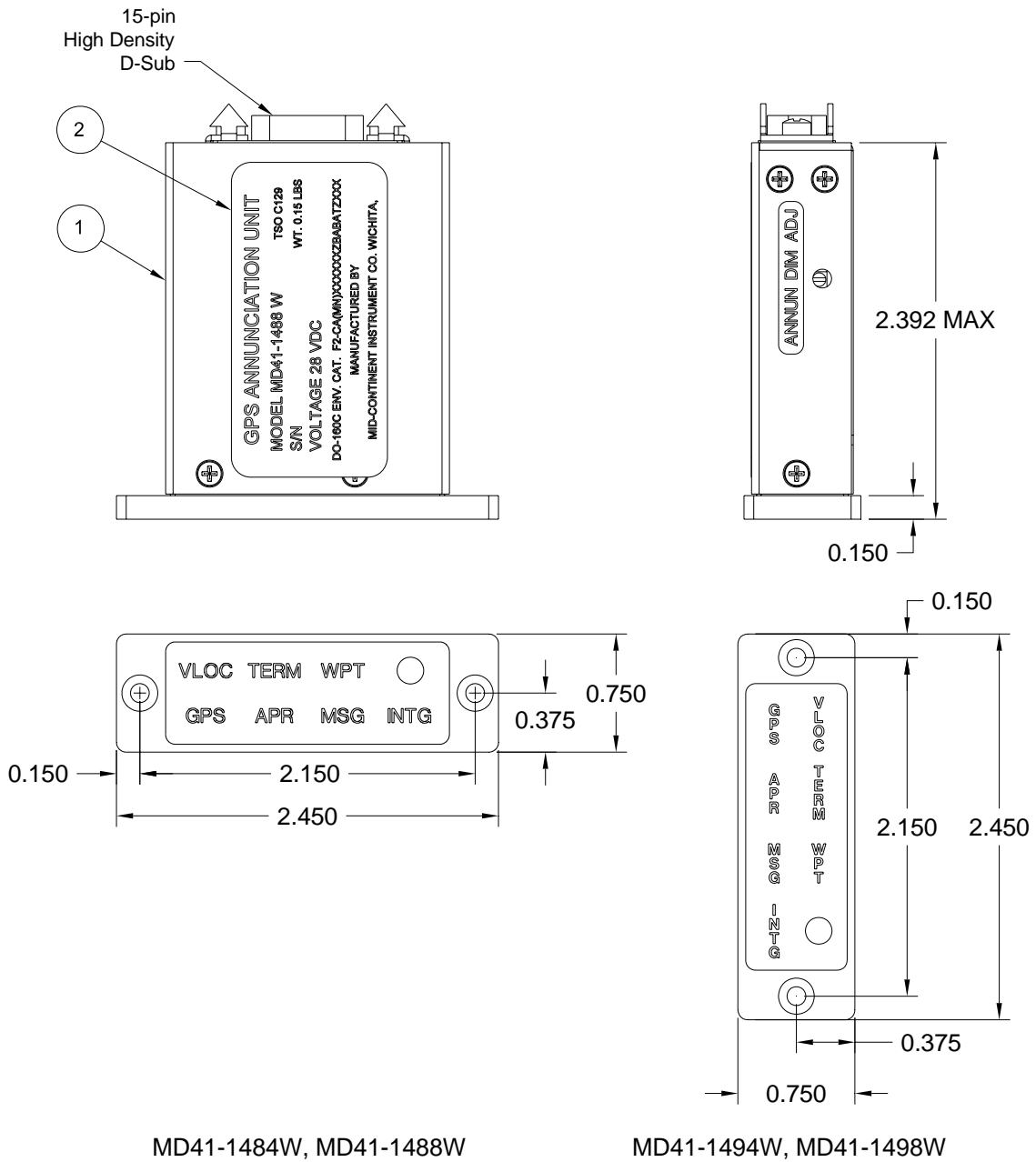
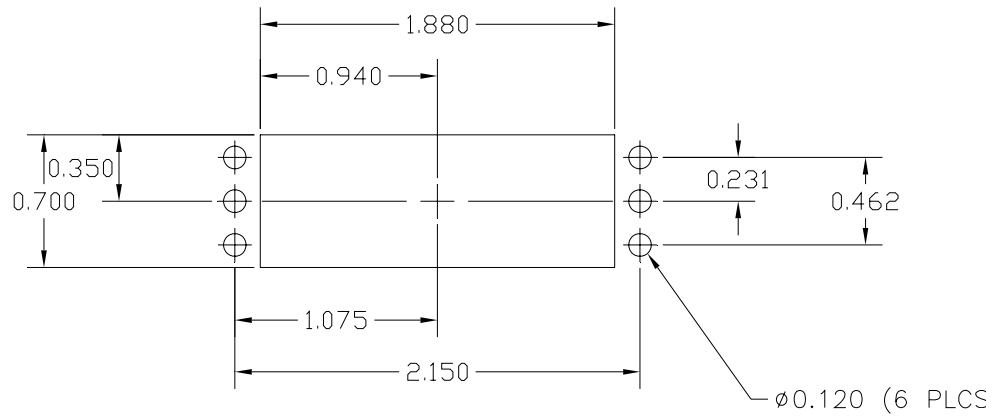

FIGURE 3-2 OUTLINE DRAWING



PANEL CUTOUT

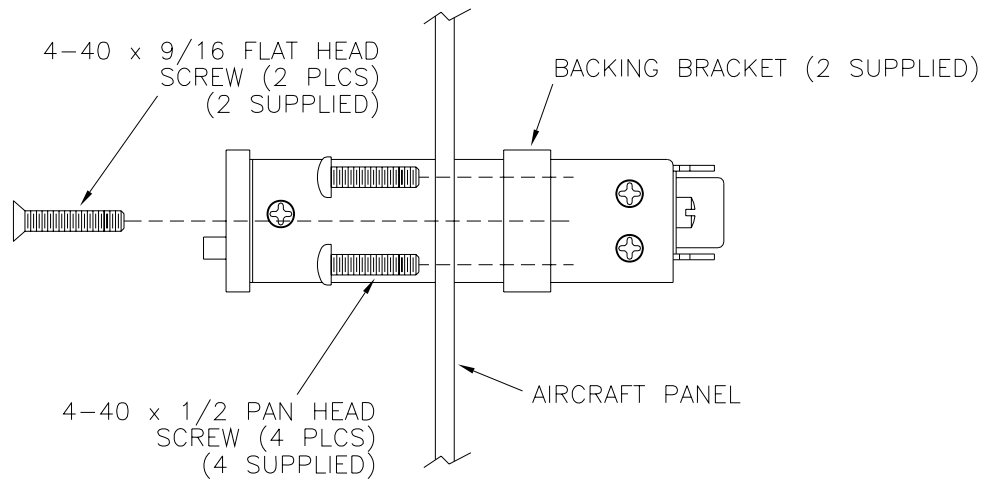
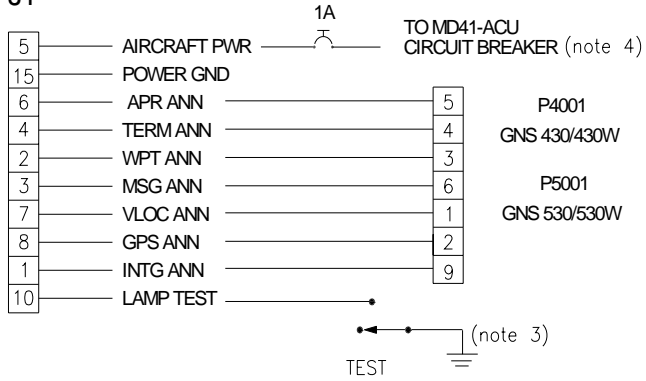

FIGURE 3-3 INSTRUMENT PANEL MOUNTING

MD41-() ACU

J1



NOTES:

- 1) REFER TO GARMIN GNS 430, 430W or GNS 530, 530W INSTALLATION MANUAL FOR ACTUAL INSTALLATION.
- 2) ALL WIRING SHALL BE 24 AWG UNLESS OTHERWISE NOTED.
- 3) MOMENTARY SWITCH FOR TEST. (optional connection)
- 4) 14 VDC FOR MD41-1484W/1494W. 28 VDC FOR MD41-1488W/1498W.

**FIGURE 3-4: WIRING DIAGRAM, MD41-1484W/1488W/1494W-1498W
For GARMIN GNS 430/430W/530/530W**

SECTION 4: POST INSTALLATION CHECKOUT

4.1 PRE INSTALLATION TESTS

With the MD41-() disconnected, turn on the avionics master switch and verify that aircraft power is on pin 5. Using an ohmmeter, verify pin 15 is aircraft ground.

4.2 OPERATING INSTRUCTIONS

Turn off the avionics master switch and connect the mating connector to the rear of the MD41-(). Turn on the avionics master switch and the MD41-() should come on with the following annunciations.

1. VLOC or GPS
2. MSG may be flashing depending on the status of the GPS receiver.

Annunciation brightness at the minimum dimming level may be adjusted by rotation of the dimmer control located on the side of the MD41-() case. CW rotation lowers the dimming level.

Refer to section 5 of the Garmin GNS 430/430W or GNS 530/530W installation manual for testing of annunciations.

No periodic maintenance or calibration is necessary for continued airworthiness of the MD41-().

DO-160C Environmental Qualification Form

NOMENCLATURE: _____ Annunciation Control Unit (ACU)
MODEL NUMBER: _____ MD41-() Series **TSO NUMBER:** C129, Class A1
MANUFACTURERS SPECIFICATIONS: _____
 _____ Minimum Performance Specification 7015613
 _____ Test Data Specification (TDS) 161, dated 2/12/07
MANUFACTURER: _____ Mid-Continent Instrument Co., Inc.
ADDRESS: _____

CONDITIONS	SECTION	DESCRIPTION OF TEST
Temperature and Altitude	4.0	Equipment tested to Category A1F2
Survival Low Temperature	4.5.2	
Operating Low Temperature	4.5.2	
Temperature Variation	5.0	Equipment tested to Category B
Humidity	6.0	Equipment tested to Category A
Operational Shocks and Crash Safety	7.0	Equipment tested to Paragraph 7.2.1
Vibration	8.0	Equipment tested to Category M and N
Explosive Atmosphere	9.0	Equipment identified as category X, no test performed.
Waterproofness	10.0	Equipment identified as category X, no test performed.
Fluids Susceptibility	11.0	Equipment identified as category X, no test performed.
Sand and Dust	12.0	Equipment identified as category X, no test performed.
Fungus	13.0	Equipment identified as category X, no test performed.
Salt Fog	14.0	Equipment identified as category X, no test performed.
Magnetic Effect	15.0	Equipment tested to Category Z
Power Input	16.0	Equipment tested to Category B
Voltage Spike	17.0	Equipment tested to Category A
Audio Frequency Conducted Susceptibility	18.0	Equipment tested to Category B
Induced Signal Susceptibility	19.0	Equipment tested to Category A
Radio Frequency Susceptibility (Radiated and Conducted)	20.4 20.5	Equipment tested to Category T
Emission of Radio Frequency Energy	21.0	Equipment tested to Category Z
Lightning Induced Transient Susceptibility	22.0	Equipment identified as category X, no test performed.
Lightning Direct Effects	23.0	Equipment identified as category X, no test performed.
Icing	24.0	Equipment identified as category X, no test performed.